

NOTES:

Square Top Mainsail as shown is required to be Class legal. Roach to be no more than 14" and 26" where shown, (14" and 28" with F-28R).

Mainsail is designed to be almost flush with the top of the mast as shown -do not shorten luff, which has cutout as shown for halyard clearance.

Vertical Batten to be used at head to ensure head stands vertical.

Tack cutaway to be as shown

Mainsail has 2 sets of reefpoints, first set positioned as shown, second set optional.

Mainsail to have Cunningham eye fitted

Class emblem located and sized as shown.

Mainsail battens to be parallel with boom or only slightly angled up as shown for easy roller furling. Upper battens to have more angle as shown.

Jib to have four leach battens placed at equal distance on leach.

Jib hanks to be for 9/32" wire

All sails are to be fitted with telltales.

All eyelets and reinforcing must be extra heavy to suit the very high loads possible with a multihull.

Changes 3/15/97

F-28R Mainsail:
Leach 36.9 changed to 37'
Luff 35.8' changed to 35' 9"

4/20/97

Wear patch added to jib
7/28/97 Rod insert added to boltrope at headboard
4/9/98 Reef points redefined
12/28/98 - Note added on bolt rope and slides
Note added on strength of eyelets.

4/10/98: Reef points best located where shown to locate headboard at reinforced track area of carbon mast when reefed

Sail	Luff	Leach	Foot	Area	Remarks	Material
Mainsail	33.8' 10300	35.1' 10700	12.0' 3660	300sq.ft 27.9sq.m.	32" head 26" roach	Technora
Jib	30.1' 9175	26.9' 8200	12.4' 3780	175sq.ft 16.3sq.m.	LP 11'	Technora
Asymmetric Spinnaker	40.2' 12250	35.8 10910	27.6' 8410	780sq.ft 72.5sq.m.		Nylon
Screacher	34' 10360	28.7' 8750	23.6' 7190	358sq.ft 33.3sq.m.	3/16" wire or 5/16" Kevlar Luff	Mylar
F-28R Mainsail	35.8' 10910	37' 11280	12.1 3690	321sq.ft 29.8sq.m.	32" head 28" roach	Technora

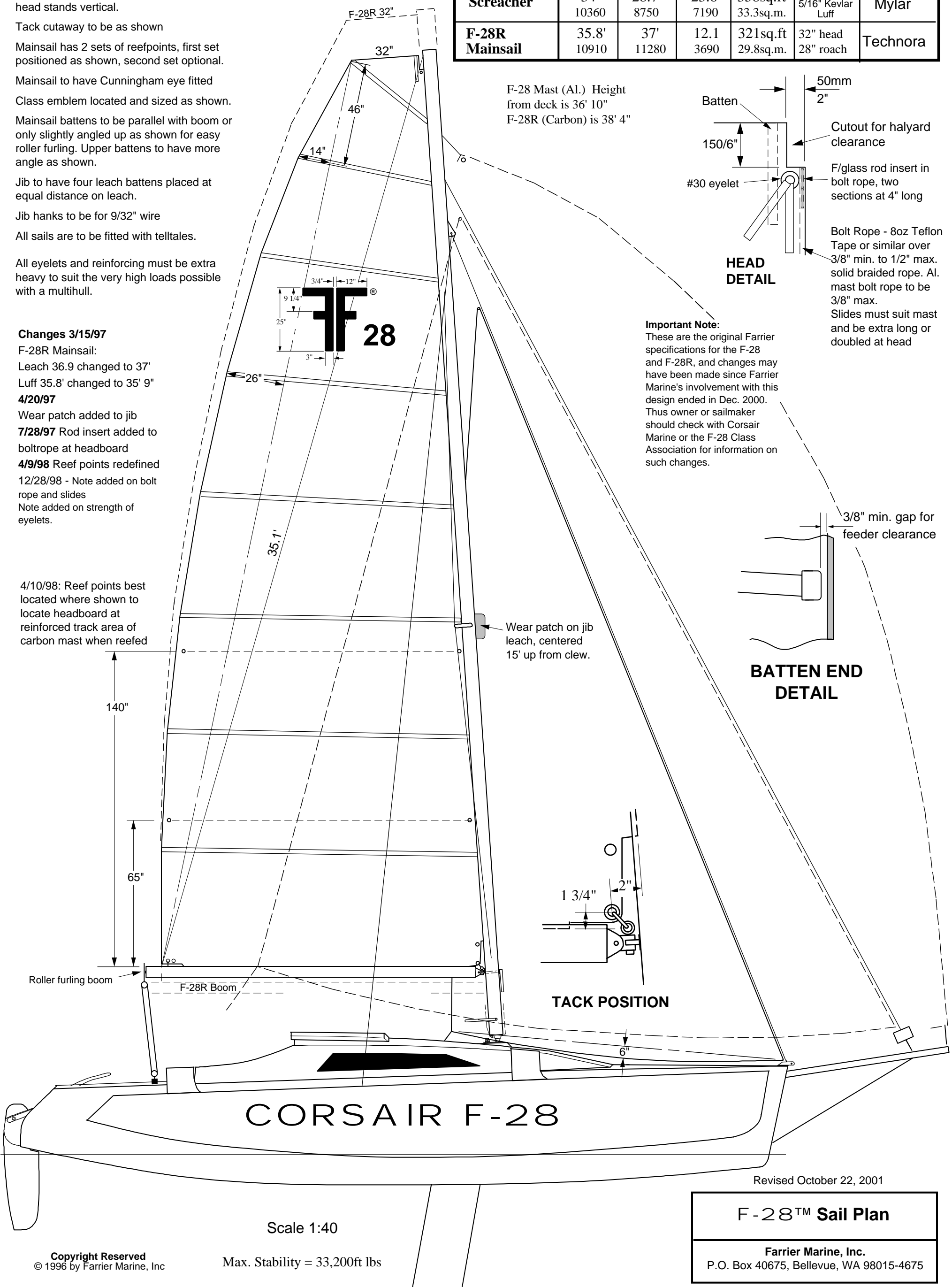

F-28 Mast (Al.) Height from deck is 36' 10"
F-28R (Carbon) is 38' 4"

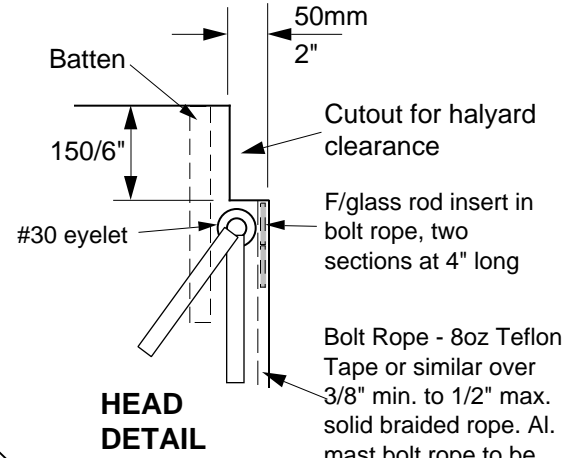

Important Note:

These are the original Farrier specifications for the F-28 and F-28R, and changes may have been made since Farrier Marine's involvement with this design ended in Dec. 2000. Thus owner or sailmaker should check with Corsair Marine or the F-28 Class Association for information on such changes.

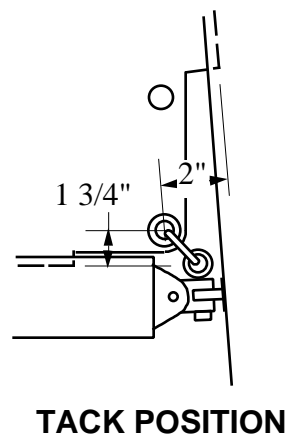
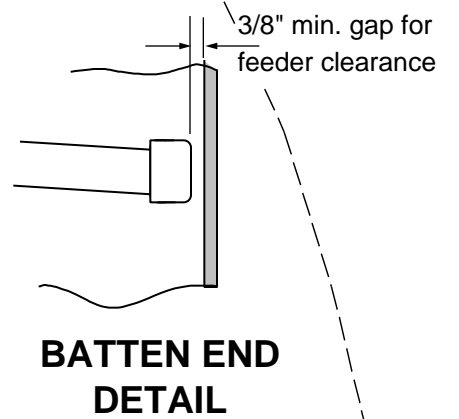

Revised October 22, 2001

F-28™ Sail Plan
Farrier Marine, Inc. P.O. Box 40675, Bellevue, WA 98015-4675

Scale 1:40

Max. Stability = 33,200ft lbs

Copyright Reserved
© 1996 by Farrier Marine, Inc